

# QUADTEK M721

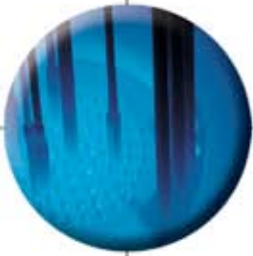

## *Remote Auto Iris Controller*



### **Features**

- Video image contrast adjustment
- Locate next to monitor in the control room
- Simple connection, shares same coax as camera

Normal operation of an industrial process such as a utility boiler or kiln includes a wide variation of operating loads from cold start-up to full load. Even the most versatile of auto-iris cameras cannot compensate for these changing light levels. The Quadtek **M721** auto-iris controller allows the operator to make level adjustments to the Lynx camera auto-iris from the control room. Level control of the auto-iris means that flame details will not be lost due to camera saturation. During start-up, burner viewing will not be lost due to insufficient levels of brightness.

Connection is made simple because the M721 controls the cameras iris while sharing the same coax that is normally run from the camera to the control room.

## Specifications and Performance

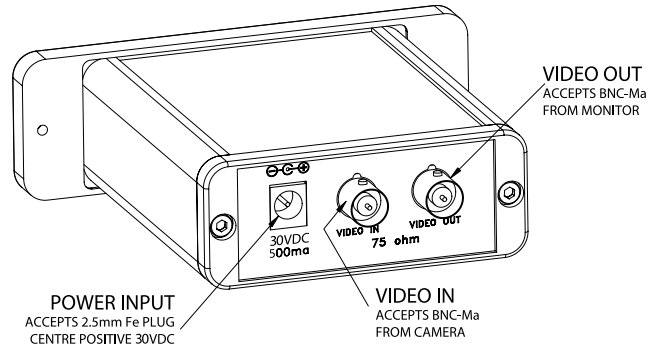
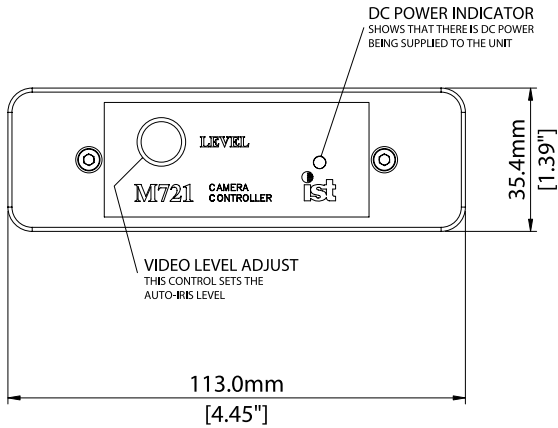

Power Requirements.....	30Vdc; 500mA via 100-240 Vac power adpator
Physical Dimensions .....	1.28" H x 3.50" W x 4.25" D (33mm x 89mm x 108mm)
Installation Clearances .....	3.0" in rear (76mm)
Operating Temperature Range.....	32 to 121° F (0 to 50° C)
Storage Temperature Range .....	-13 to 158° F (-25 to 70° C)
Relative Humidity.....	0 to 95%
Camera Requirements.....	Quadtek Lynx camera with remote iris control option
Video Input.....	1 channel 75 ohm composite video with BNC connector
Video Output .....	1 channel 75 ohm composite video with BNC connector

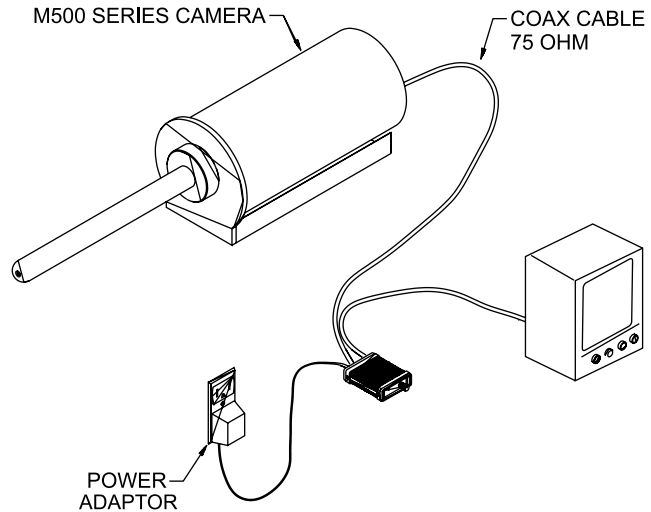

## Imaging and Sensing Technology Corporation

204 IST Center  
Horseheads, NY 14845 USA  
Tel: 607-562-4300  
800-432-1478  
Fax: 607-562-4392  
E-mail: sales@quadtek.com

19501 144th Avenue NE, Suite F1100  
Woodinville, WA 98072 USA  
Tel: 425-881-0778  
Fax: 425-869-0667  
E-mail: sales@quadtek.com

12954 Stonecreek Drive, Suite C  
Pickerington, OH 43147 USA  
Tel: 614-367-2050  
Fax: 614-367-2464  
E-mail: sales@quadtek.com

Station Road  
Alton, Hampshire  
GU34 2PZ, UK  
Tel: 01420 541600  
Fax: 01420 541700  
E-mail: info@istcorp.co.uk